

SHIELD TECH SECURITY FAI-820 and FAI-586 DIAGRAMS

www.shieldtechsecurity.com (Revision 1.0)

CONNECTING FAI-820 to FAI-586 DIAGRAM

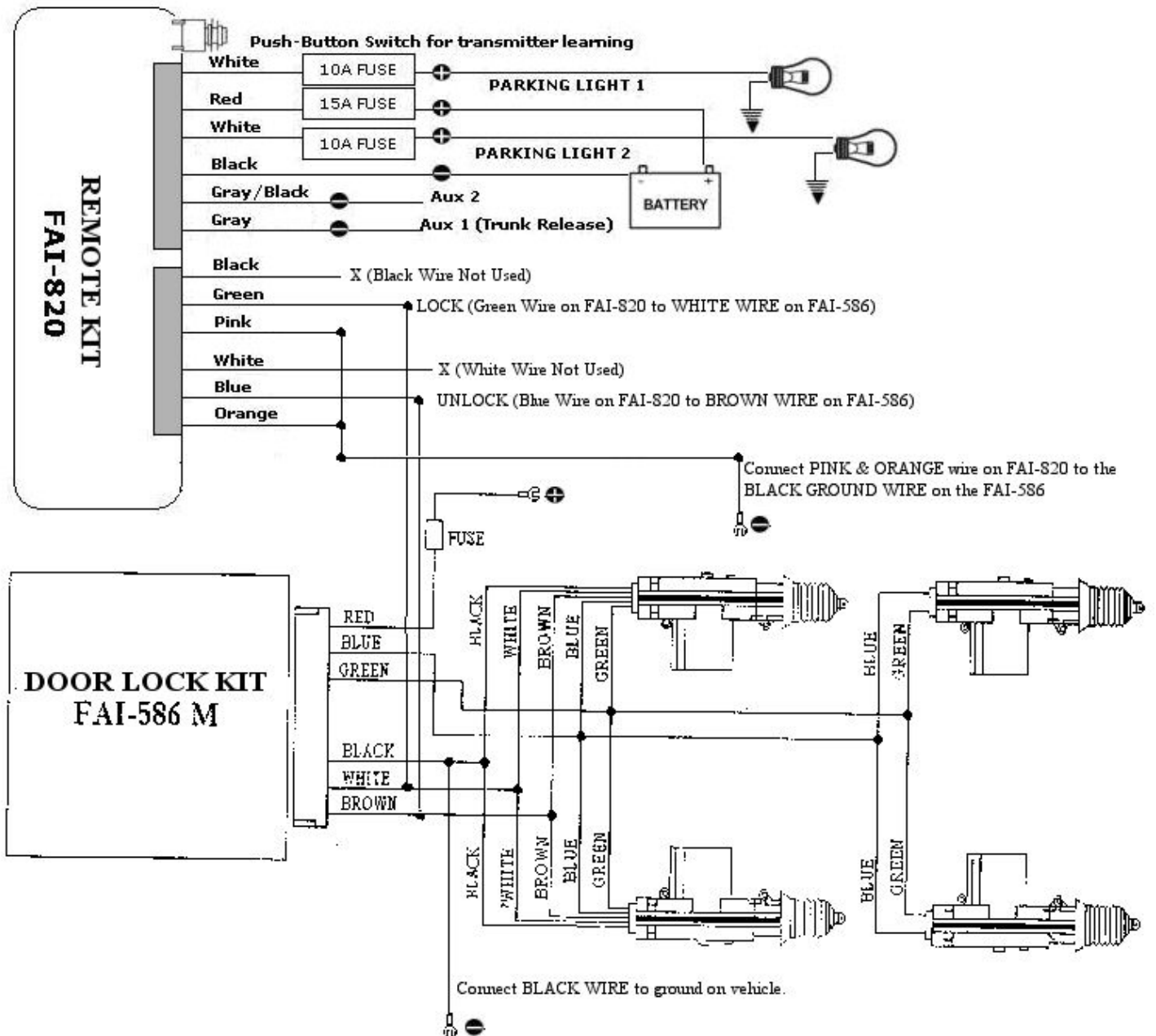

Installations should be attempted by experienced security installers only. Information contained is without any representation of warranty. Proper installation remains the sole responsibility of the installer. Shield Tech Security assumes no liability or responsibility resulting from an improper installation, even in reliance with the information contained in this guide.

FAI-820 WIRING DIAGRAM

Keyless Entry System

Remote Module

2-Button or 4-Button Remoter available

Features:

1. Remote door lock/unlock
2. Car finder
3. Total closure
4. Remote trunk open
5. Programmable remoter code learning(Push button)
6. 1 or 4 sec. lock time adjustable(Jumper)
7. 2 indicator outputs

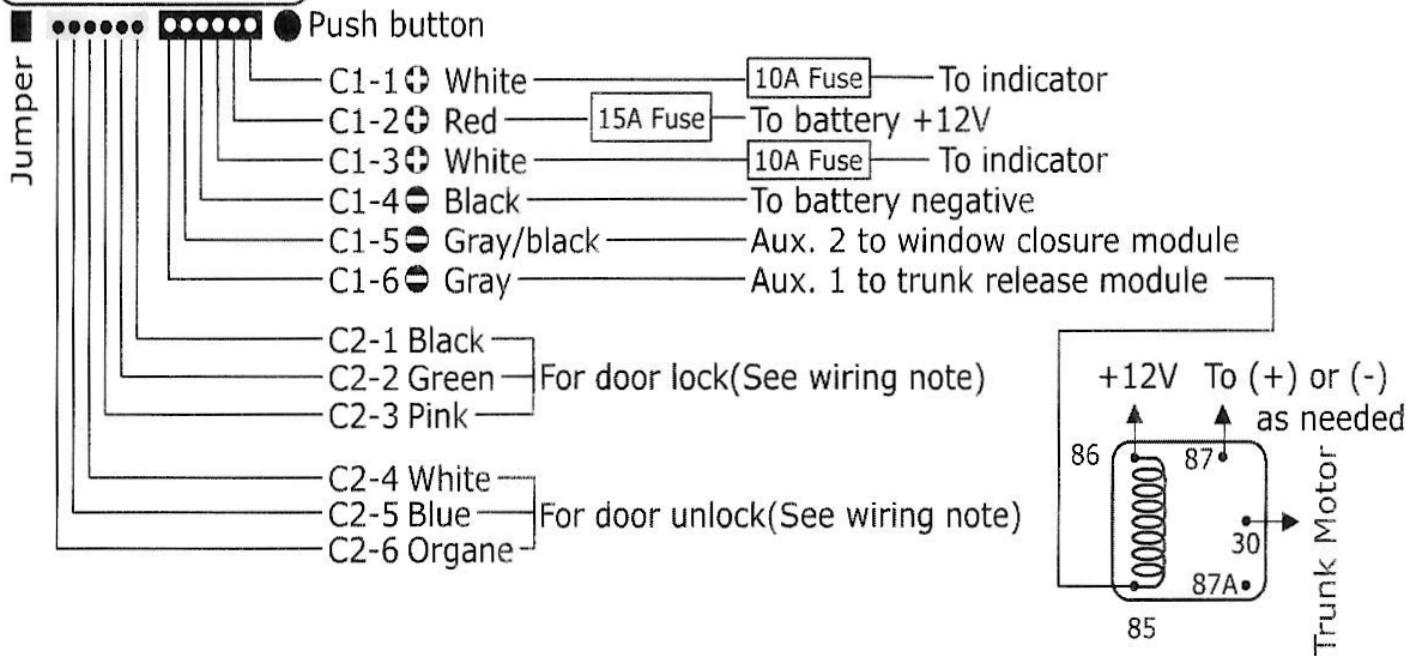
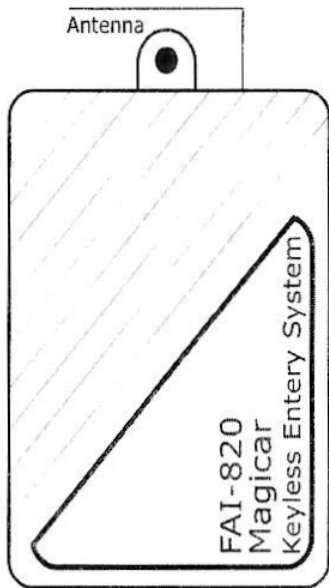

Installations should be attempted by experienced security installers only. Information contained is without any representation of warranty. Proper installation remains the sole responsibility of the installer. Shield Tech Security assumes no liability or responsibility resulting from an improper installation, even in reliance with the information contained in this guide.

FAI-820 Wiring Note

Central door Lock Wiring Diagram

Diagram #A
Original built-in central power lock

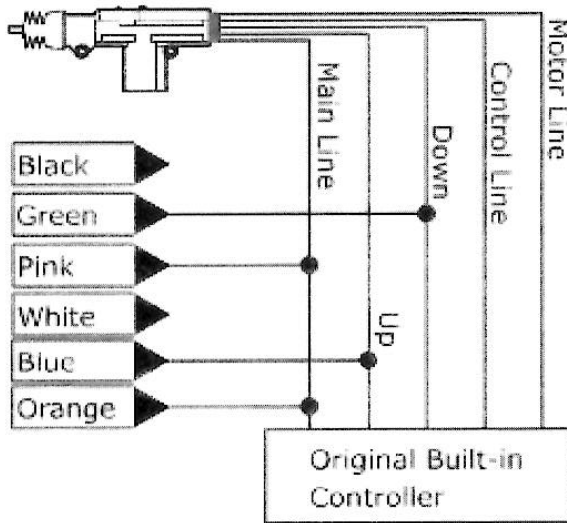

Diagram #B
Original built-in central power lock & electric power lock switch were installed
For example: CHRYSLER

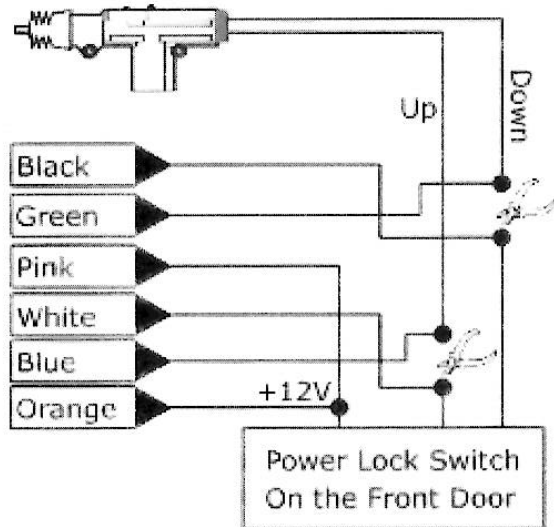

Diagram #C
Original built-in central power lock & only a switch existed inside of the front door.
A motor and the control level were required

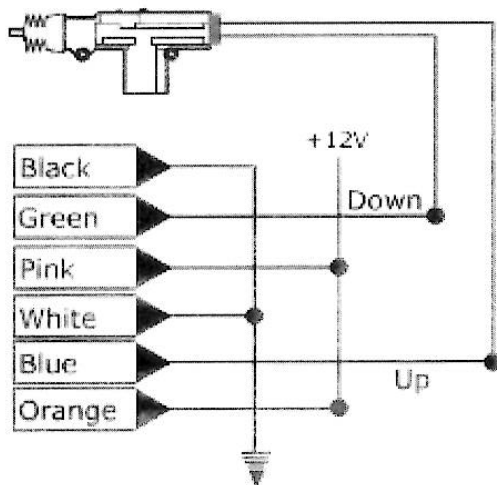
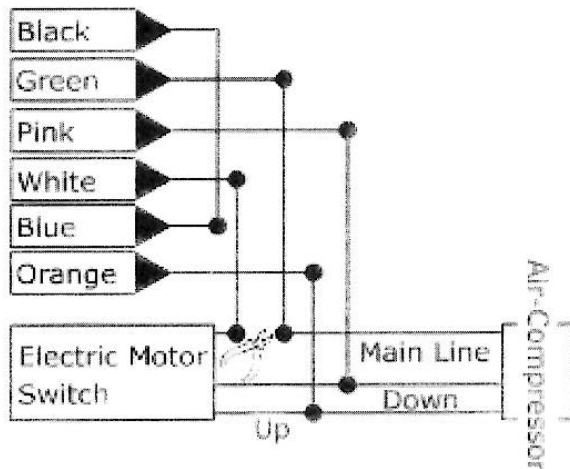
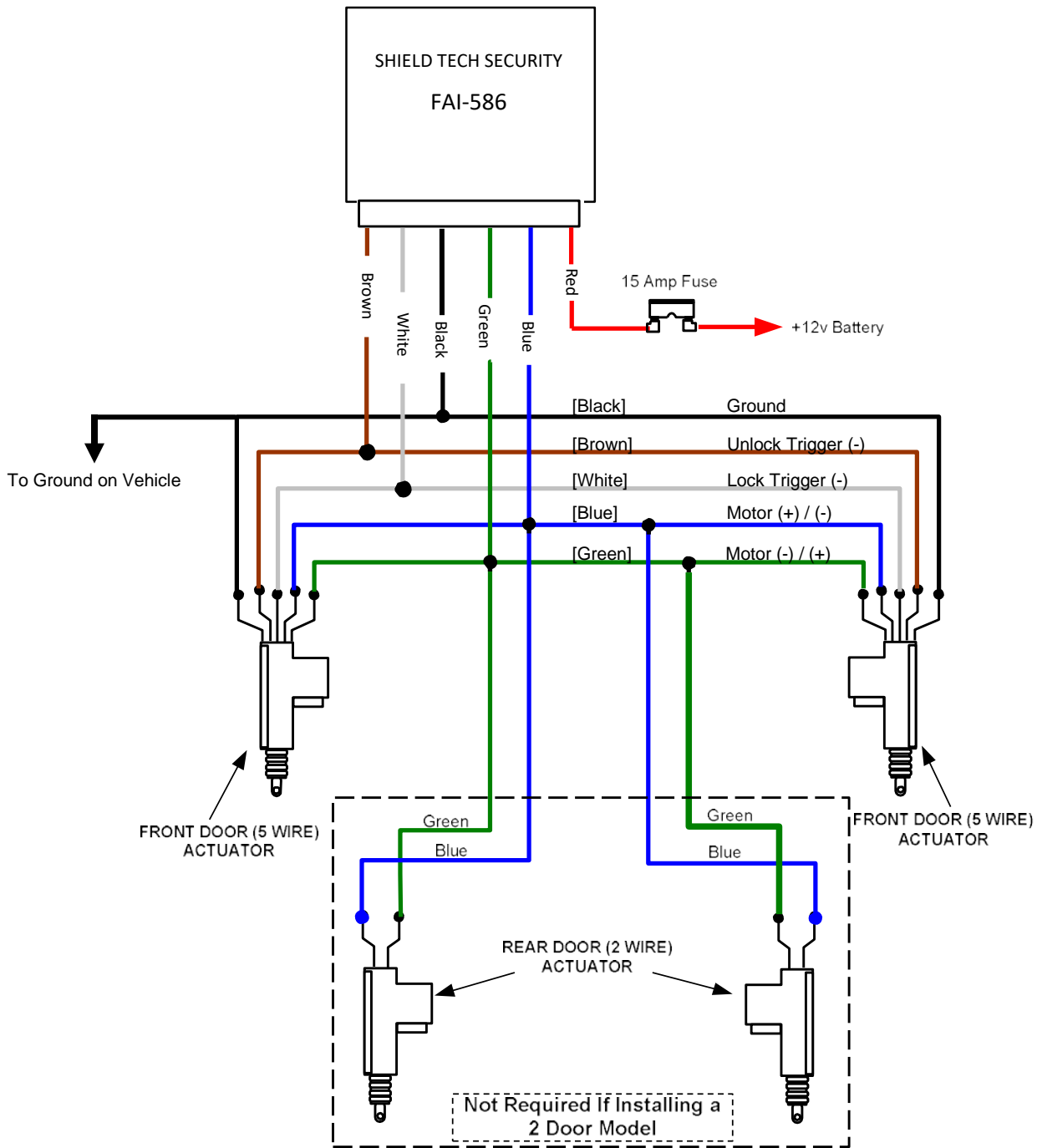

Diagram #D
Original built-in power lock & using compressor to control the switch.
For example: BENZ, AUDI
(Note: Active time 3.5 sec.)



Installations should be attempted by experienced security installers only. Information contained is without any representation of warranty. Proper installation remains the sole responsibility of the installer. Shield Tech Security assumes no liability or responsibility resulting from an improper installation, even in reliance with the information contained in this guide.

FAI-586 WIRING DIAGRAM



MORE INFORMATION

Please visit www.shieldtechsecurity.com for more information.

Installations should be attempted by experienced security installers only. Information contained is without any representation of warranty. Proper installation remains the sole responsibility of the installer. Shield Tech Security assumes no liability or responsibility resulting from an improper installation, even in reliance with the information contained in this guide.