

SHIELD TECH SECURITY FAI-330 and FAI-587 DIAGRAMS

www.shieldtechsecurity.com (Revision 1.3)

CONNECTING FAI-330 to FAI-587 DIAGRAM

CAR ALARM w/ DOOR LOCK KIT WIRING DIAGRAM

SHIELD TECH SECURITY FAI-330 w/ FAI-587

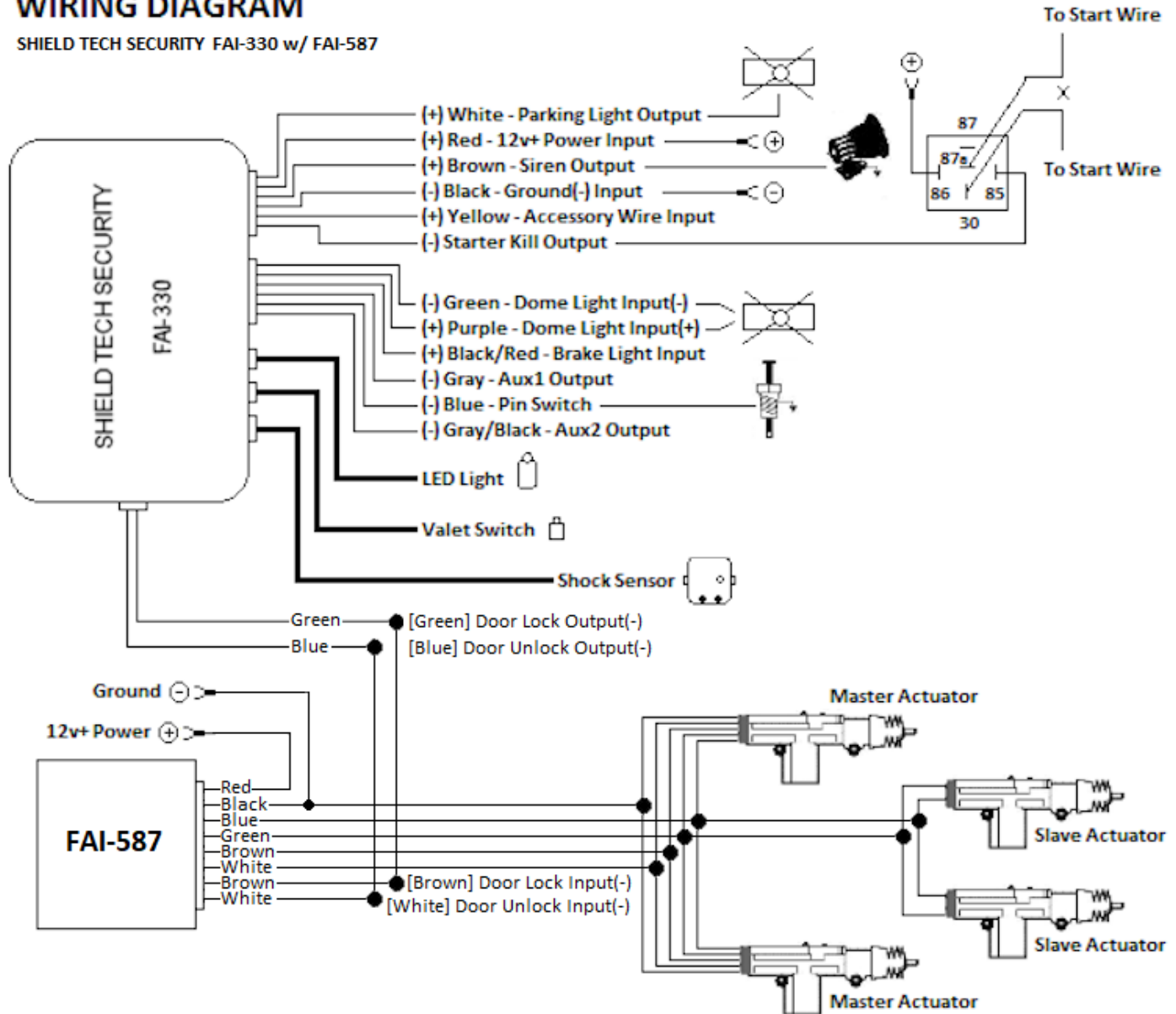

FREE VEHICLE WIRING DIAGRAM – FREE 30 DAY ACCESS

Reference the vehicle wiring diagram insert. Free access is available 30-days from your purchase date.

If you need access to our vehicle wiring diagrams after 30-days, please purchase one at the link below.

www.shieldtechsecurity.com/vehicle-diagram

Installations should be attempted by experienced security installers only. Information contained is without any representation of warranty. Proper installation remains the sole responsibility of the installer. Shield Tech Security assumes no liability or responsibility resulting from an improper installation, even in reliance with the information contained in this guide.

FAI-330 WIRING DIAGRAM

FAI-330

2 or 4 buttons

Vehicle Security System

- *Window closure
- *Footbrake lock
- *Dual stages shock sensor
- *Negative or positive pulse for lock or unlock
- *Auxiliary channel #2 output
- *Auxiliary channel #3 output

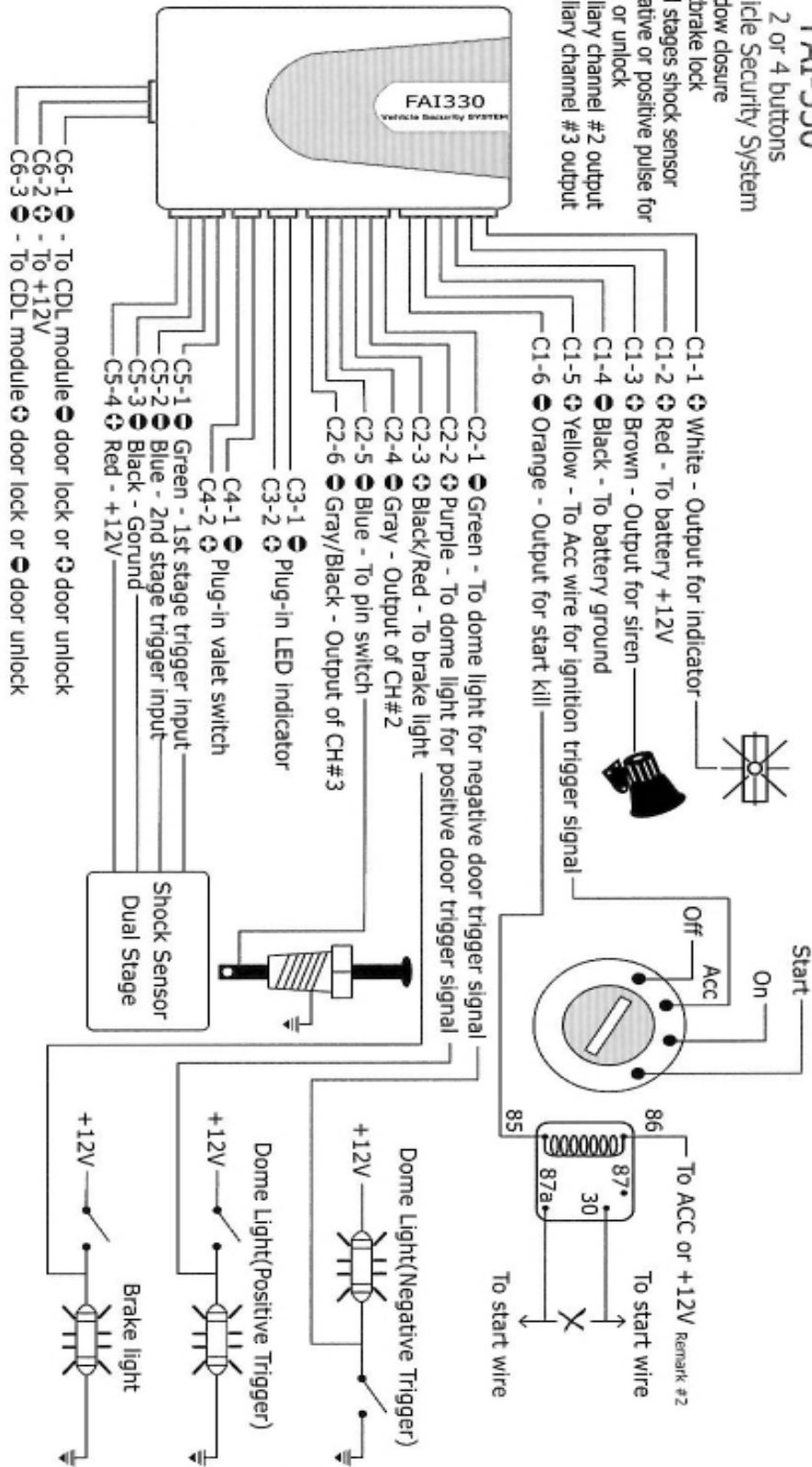

Remark:

1. Connects either C2-1 or C2-2 depends on the vehicle's dome light which is positive or negative trigger
2. Star Kill relay:

*If connect #86 to Acc, under the armed mode, the start kill relay will be on only when the Acc is on (Economical mode)
 *If connect to +12V, the start kill relay will be on when the system is armed

Installations should be attempted by experienced security installers only. Information contained is without any representation of warranty. Proper installation remains the sole responsibility of the installer. Shield Tech Security assumes no liability or responsibility resulting from an improper installation, even in reliance with the information contained in this guide.

FAI-587 WIRING DIAGRAM

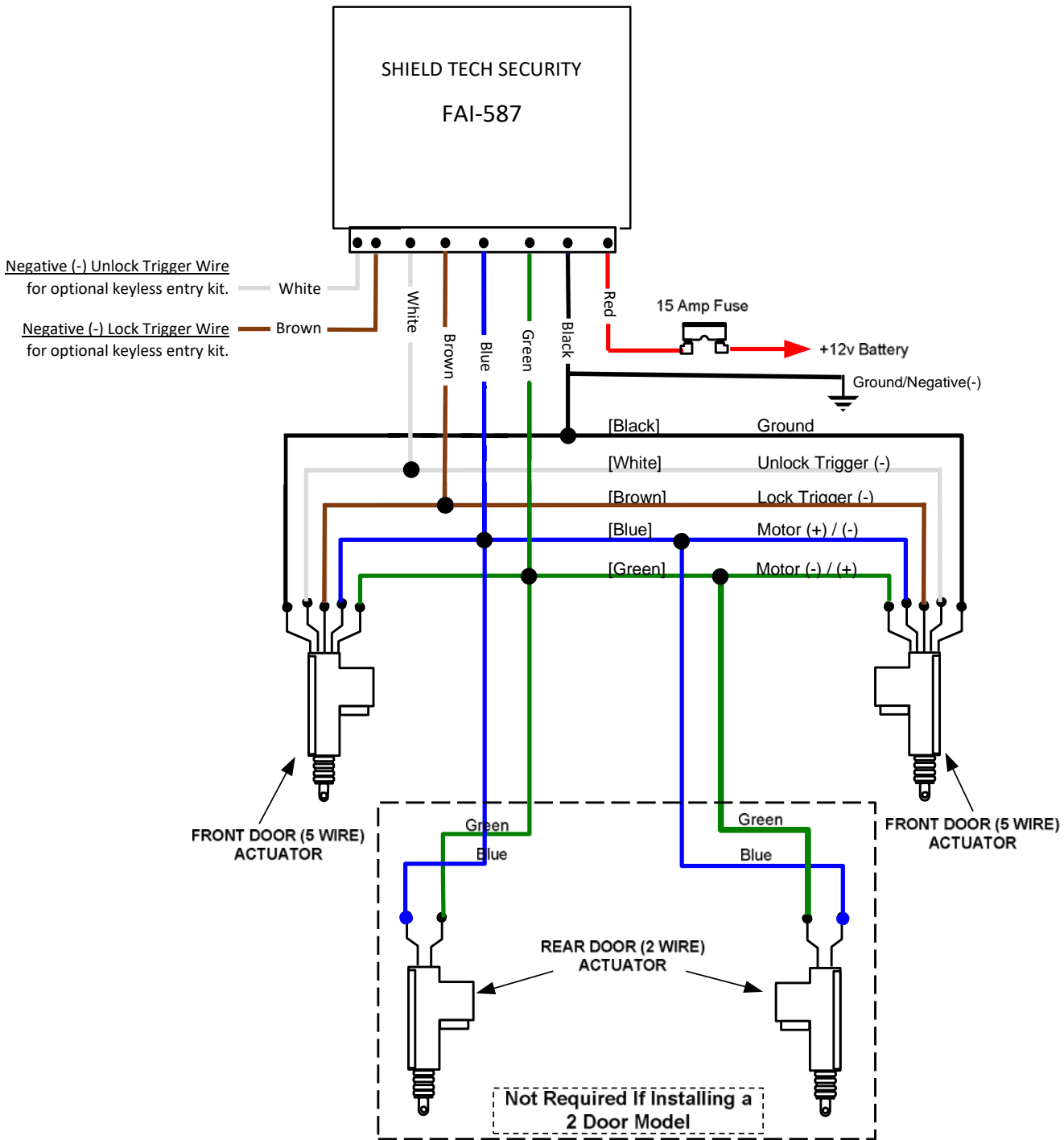

MORE INFORMATION

Please visit www.shieldtechsecurity.com for more information.

Installations should be attempted by experienced security installers only. Information contained is without any representation of warranty. Proper installation remains the sole responsibility of the installer. Shield Tech Security assumes no liability or responsibility resulting from an improper installation, even in reliance with the information contained in this guide.