

***FAI-8100***  
***2-Way Color LCD FM technology Security System***

***Owner's Manual***

**Table of Contents:**

<b><i>Introduction</i></b> .....	<b>2</b>
<i>Features</i> .....	2
<i>Key Function Table</i> .....	3
<i>Color LCD Transmitter</i> .....	3
<i>Indications of Icons</i> .....	4
<b><i>System Features</i></b> .....	<b>4</b>
<i>Remote Transmitter Code Learning</i> .....	4
<i>Remote Arm</i> .....	5
<i>Enhanced System Alerts</i> .....	5
<i>Panic Mode</i> .....	5
<i>Trunk Release</i> .....	5
<i>Car Finder</i> .....	5
<i>Mute Arm Mode</i> .....	5
<i>Remote Valet Mode</i> .....	6
<i>Emergency Override Mode</i> .....	6
<i>Shock Sensor Bypass</i> .....	6
<i>RPM (Tach) Learning</i> .....	6
<i>Remote Engine Start for Automatic Transmissions</i> .....	6
<i>Reservation Mode (Remote Engine Start for Manual Transmissions Only)</i> .....	7
<i>LCD Remote Transmitter Function</i> .....	7
<i>Factory Alarm Disarm Output</i> .....	7
<i>Immobilizer By-pass Output</i> : .....	7
<b><i>Optional Programming Features</i></b> .....	<b>8</b>
<i>Programming Option Table</i> .....	8
<i>Last Door Arming</i> .....	8
<i>Passive Lock</i> .....	9
<i>Ignition lock</i> .....	9
<i>Door Unlock Time</i> .....	9
<i>Siren or Horn Output</i> .....	9
<i>Alarm Time</i> .....	9
<i>Dome Light Delay</i> .....	9
<i>Auto Re-Arm</i> .....	10
<i>Anti-Hijacking Mode</i> .....	10
<i>Car Type</i> .....	10
<i>Engine Start Mode</i> .....	10
<i>Crank Time</i> .....	10
<i>Start Running Time</i> .....	10
<i>24-Hour Engine Start Mode</i> .....	10
<b><i>Wiring Diagram</i></b> .....	<b>12</b>

## ***Introduction***

The Magicar FAI-8100 is the unique Auto Security Remote Start System incorporated with Super FM Paging Circuit, designed to provide you with the highest level of security for your vehicle and convenience for your auto life.

Thanks for the two-way interactive communications system built in, a small palm size LCD remote transmitter will report you instantly through the audible alert and visual icon display if detected for the violated zones on your vehicle such as impact, door open, hood open, truck open as well as the ignition on.

The Magicar FAI-8100 has many functions you can choose from to customize your needs. So read this owner manual carefully before you operate the Magicar FAI-8100 system.

## ***Features***

1. 1 Two Way LCD Remote Transmitter and 1 one way 2<sup>nd</sup> remote
2. Code Hopping and Code Learning Remote System
3. Up to 4 LCD remote transmitters Programmable
4. Remote Engine Start
5. Remote Arm/Disarm
6. Mute Arm/Disarm
7. Starter Kill (500mA negative output) in arming mode
8. Remote Trunk Release
9. Passive or Active Lock Programmable
10. Auto Re-arm
11. Lock/Unlock on driving
12. Silent Car Searching
13. Vibrate or Audible Alert
14. LCD Back Light Display
15. Low level of Battery Indicate
16. Audible Intrusion Zone Identification
17. Defective Zone Alert and By-pass
18. Back-up Memory for the Battery Power Failure
19. Keyless Entry While Ignition is on
20. Remote Panic
21. Remote Hijacking – Keeping Engine on.
22. Emergency System Override
23. Remote Valet Mode
24. Last Door Arming
25. Siren Chirp programmable for 30 or 60 seconds
26. Built-In Actuators Relay
27. Tach or Tachless Sensing
28. Central Lock Active Time selectable 0.5 or 3.5 seconds
29. Plug-In Dual Stage Shock Sensor
30. Pre-warn away
31. Shock Sensor By-pass
32. Vehicle Status Report
33. Triggered Report by chirp when disarmed
34. Ignition Auto Lock/Unlock
35. Siren or Horn selectable
36. Dome Light Delay Time programmable
37. 24hr Engine start

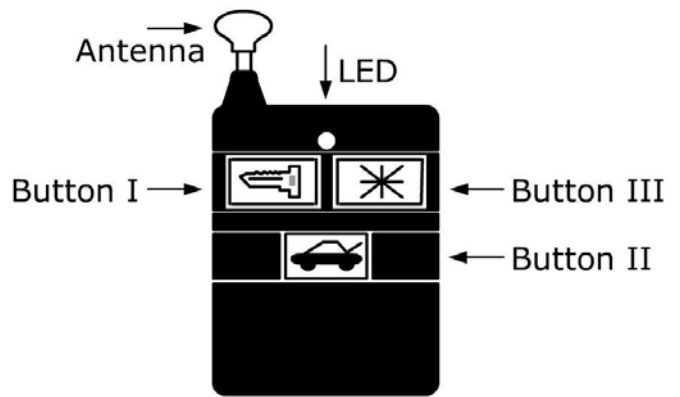
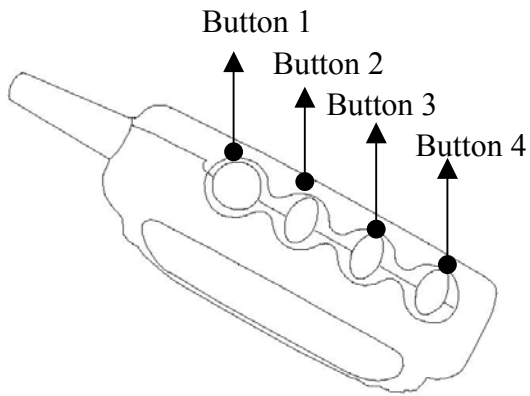

**Key Function Table**

Button	Ignition Off	Ignition On
Press Button (1) once	Arm / Disarm	Lock/ Unlock
Press Button (1) over 2 sec.	Panic	Panic
Press Button (2) over 2 sec.	Trunk Release	Trunk Release
Press Button (3) once	Car Finder	Anti-Hijacking
Press Button (3) over 3 sec.	Remote Start On/Off	
Press Button (4) once	Remote TX Back-Light On/Off	Remote TX Back-Light On/Off
Press Button (1)+(2)→ button (1)	Mute Mode	
Press Button (1)+(2)→ button (1) +(2)		Valet Mode
Press Button (1)+(3)	24-Hour Engine Start Mode	24-Hour Engine Start Mode
Press Button (2)+(3)	Status Report	Status Report
Press Button (2)+(4)	Remote TX power Saving Mode	Remote TX Power Saving Mode
Press Button (3)+(4)	Vibrate Alert On/Off	Vibrate Alert On/Off

**Color LCD Transmitter**

FAI-8100 remote transmitter provides you with the live monitoring on your vehicle 24 hours a day. As shown in the below LCD panel, the violated zones or attempt report you instantly through the LCD remote transmitter.

Or press button (2) and (3) at the same time, you can get the current status of your vehicle.

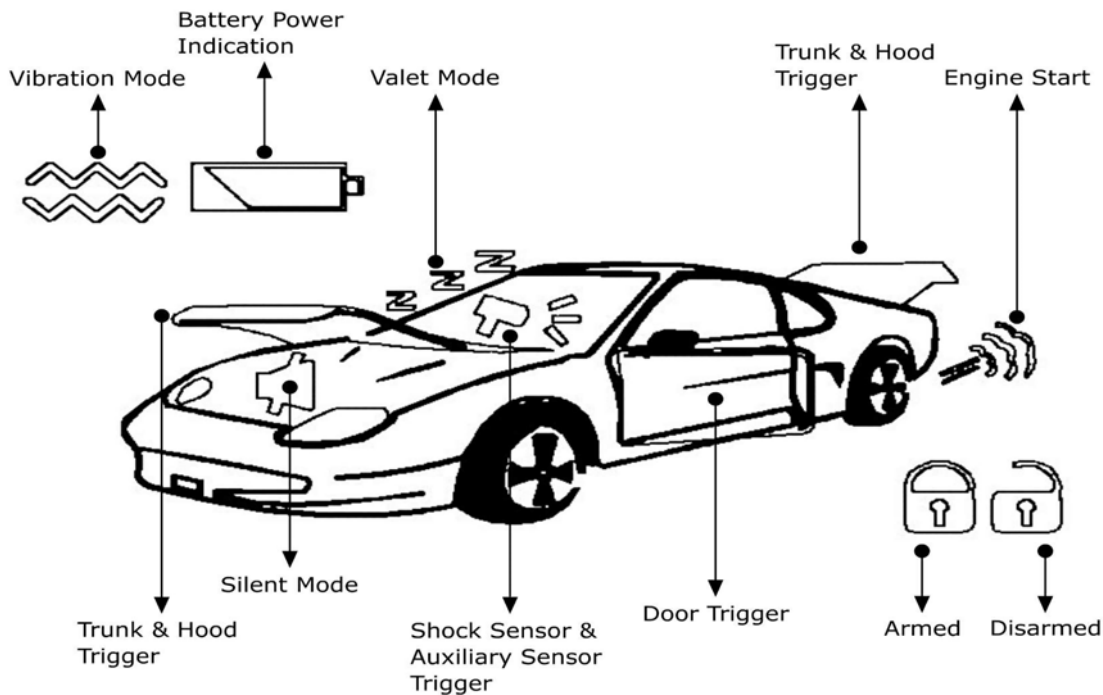

**Indications of Icons**

Icon	Indication
Battery	Low Battery Capacity
Wave	Vibration
Hood	Hood Open or Trigger
Car Siren	Mute Mode
Parking Light	Parking Light Flash
Hammer	Trigger of the First or Second Stage Shock Sensor
ZZZZ	Power Saving Mode
Trunk	Trunk Open or Trigger
Exhaust Fumes	Engine Remote Start
Door	Door Open or Trigger
Lock/Unlock	Arm/Disarm

**System Features**

**Remote Transmitter Code Learning**

Take the following procedures to perform the transmitter code learning.

- a. Under the disarm mode, close the door, switch the ignition ON/OFF 3 times and then, stay ON position. (each time shall get finished within 1second or it will skip this mode). Siren will chirp 2 times, and enter into the code learning mode.
- b. To perform the transmitter code learning, press button (1) within 10 seconds. Then the siren will chirp twice and the parking lights flash twice to confirm that the code has been learned. Take the same procedure for second, third and fourth remote transmitter.
- b. If the ignition is turned OFF or button (1) is not pressed within 10 seconds, the system will quit the code learning mode. If so, try it again from the first step.
- c. Up to 4 remote transmitters are programmable to the system.

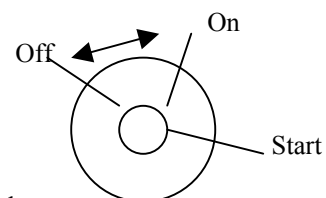

### ***Remote Arm***

To arm the system, exit the vehicle and close all doors, just press button (1) once. The siren will chirp once and the Parking lights flash once. Then, the doors will be locked and starter kill will be On and Armed. Now the system is ready to respond if intrusion attempts are detected.

If the doors, trunk or hood is opened, or the first stage shock sensor is triggered, the siren will chirp three times and the parking lights flash three times at the same time. The violated zones will be by-passed and the system enters into the arm mode.

### ***Remote Disarm***

To disarm the system, just simply press button (1) once while the system is armed.

The siren will chirp twice and the parking lights flash twice at the same time.

If triggered while the system is armed, the siren will chirp 4 times and the parking lights flash 4 times.

### ***Enhanced System Alerts***

To protect your vehicle, the system will emit the different alert under the various situations.

- a) Pre-warn sensor (first-stage sensor) triggered: Light impact will activate the pre-warn sensor. Remote transmitter will sound the three short chirps with impact icon display.
- b) Shock sensor (second-stage sensor) triggered: Heavy impact will activate the second-stage sensor. The parking lights will flash and siren sound for one cycle (30 or 60 seconds based on the programmed default).
- c) Ignition on: Siren will sound until the ignition is off.
- d) Door open and then closed: The parking lights will flash and siren sound for one cycle (30 or 60 seconds).
- e) Door open and not closed: Siren will sound for three cycles (siren will stop for 5 seconds and sound again for next cycle). Door sensors will be bypassed until they are closed.
- f) Hood or trunk open and then closed: The parking lights will flash and siren sound for one cycle (30 or 60 seconds).
- g) Hood or trunk open and not closed: Siren will sound for three cycles (siren will stop for 5 seconds and sound again for next cycle). Hood or trunk switches will be bypassed until they are closed.
- h) Alarm triggered: Press button (1), siren will chirp once, door lock and the system is still armed. Press button (1) once again, siren will chirp four times, doors unlock, start kill off and LED off or flashes rapidly.

### ***Panic Mode***

Use this mode conveniently when you are in a situation to warn away the intruders.

- a) Under the disarm mode, press button (1) 2 seconds.

The doors will be locked, starter kill on, lights flash and siren on. The system will be armed after the siren is off.

- b) Under the arm mode, press button (1) 2 seconds.

The parking light will flash and siren will sound. The system will remain armed.

- c) Under the ignition on, press button (1) 2 seconds.

The parking lights will flash and siren sound. After the ignition is off, starter kill will be on and armed.

### ***Trunk Release***

Press and hold button (2) 2 seconds either the system is armed or disarmed, trunk will be released.

### ***Car Finder***

- a) Press button (3) once either the system is armed or disarmed, the parking lights will flash 30 seconds.

- b) Press either button (1), (2) or (3) while the system is under this mode. Siren will chirp once and the parking lights flash once, and then the system will be armed if under disarmed before.

### ***Mute Arm Mode***

From the disarm mode, Press button (1) and (2) simultaneously, lights will flash once, then press button (1) once again within a second. (LCD TX chirps one long sound, display mute and lock icon.)

- a) Warn away sensor triggered: siren will chirp three times and send triggered signal to the remote transmitter in order to inform that the vehicle is impacted lightly.
- b) Second-Stage Shock Sensor triggered: The parking lights will flash, but siren will not sound. The lights will be off after flashing one cycle and the system will remain still under the mute arm mode.
- c) Ignition Trigger (when ignition is on): The parking lights will flash and siren sound. Lights and siren will stop

flashing and sounding until the ignition is off.

- d) Door open and then closed: The lights will flash and siren sound. The lights and siren will be off after one siren-sounding cycle and the system will remain still under the mute arm mode.
- e) Door open and not closed: The parking lights and siren will be on for three cycles, and door sensors will be bypassed until doors are closed properly, then the system remains under the mute arm mode.
- f) Hood or trunk open and closed: The parking lights will flash but the siren not sound. Lights will stop flashing after one siren-sounding cycle and the system remains under the mute arm mode.
- g) Hood or trunk open and not closed: The parking lights will flash for the three cycles, siren not sound, and hood or trunk switches will be bypassed until they closed properly, then the system remains under the mute arm mode.
- h) When the alarm is triggered, press button (1) once, lights will stop flashing. Press button (1) once again, the siren will chirp 4 times, lights flash 4 times, doors unlock, start kill off, LED off or flashes rapidly, the system will quit the mute arm mode.

### ***Remote Valet Mode***

This mode is a convenient feature to use when you hand the remote transmitter to third person for valet parking or vehicle service.

When the system is disarmed, switch the ignition on and press button (1) and (2) once simultaneously, the light will flash once. Then press button (1) and (2) once again simultaneously within 2 seconds, the siren will chirp once and then the system enters into the valet mode. Under this mode, drivers can control only door lock/unlock.

To quit the remote valet mode, switch the ignition on and press button (1) and (2) once simultaneously, lights will flash once. Then press button (1) and (2) once again simultaneously within 2 seconds, the siren will chirp twice and then the system will quit the valet mode.

### ***Emergency Override Mode***

As an emergency situation happens like the remote transmitters lost, you can override the full security system.

- a) Open the door by your car key and the alarm will be triggered.
- b) Switch the ignition on/off 4 times

As soon as possible, visit and consult with one of the service centers of FAI-8100 product.

### ***Shock Sensor Bypass***

Press button (1) once under the disarm mode and press again button (1) within 2 seconds.

### ***RPM (Tach) Learning***

Before perform the RPM(Tach) learning, turn off all electrical devices such as car stereo, FM Radio or air conditioner. By doing so, the system will learn lower RPM, which will make it smoother and easier when remote starts.

Take the following steps to perform the RPM learning.

- a) Shift the gear to the neutral position and pull up the hand brake.
- b) Switch the ignition on and start the engine.
- c) Wait until the PRM is running stably (normally vehicle's stable RPM is 900-1,000.)
- d) Press button (3) 3 seconds. The parking lights will flash 2 seconds and then flash twice to confirm that RPM is learned.

### **Important:**

- 1. Please make sure to default Start Mode as Tach (please refer to # 11 Start Mode Select of Programming Option section).**
- 2. The Tach wire (Green) of the alarm system shall be connected to the negative of the coil.**

### ***Remote Engine Start for Automatic Transmissions***

Just press button (3) 3 seconds to remote start.

If the remote start has not been successful more than twice, please check up the followings.

- a) The remote start will be activated only under the arm mode.
- b) Hood Open
- c) Trunk Open
- d) Door Open
- e) Foot brake pushed down
- f) Hand brake pulled down

The engine will shut off if the following cases happen to protect your vehicle after the remote start.

- a) Hood Open
- b) Door Open
- c) Trunk Open
- d) Foot brake pushed down

- e) Parking brake released

After remote engine start is succeeded, please follow the following steps to enter the vehicle.

- a) Disarm/unlock first.
- b) Insert the car key into the ignition then switch it to “On”, not Start.

**The engine will shut down if apply foot or hand brakes before insert the car key into the ignition and switch “On”.**

#### ***Reservation Mode (Remote Engine Start for Manual Transmissions Only)***

For the safety concern, the reservation mode is designed for the manual transmission cars.  
The manual transmission shall be defaulted (refer to Car Type of Programming Option Section)

Take the following procedure to set up the reservation mode.

1. After arriving at the destination, remain the ignition on and shift the gear to the neutral position
2. Pull up the parking brake.
3. Remove the key from the ignition. The engine will keep running.
4. Exit the vehicle and close the door after taking Step# 3. Then the engine will shut down and the reservation mode is set up.

**Important:** Reservation mode must be set up every time before exiting manual transmission cars in order to remote start.

#### **Important requirements to activate the reservation mode:**

1. The transmission gear must be placed in the **neutral** position.
2. The hand brake must be pulled up.
3. Do not set the reservation mode when people are in vehicles.
4. Do not activate the remote engine start when people are in vehicles
5. The remote engine start will only be activated when the system is armed.

#### **Cancel the Reservation Mode**

The reservation mode will be cancelled if the following cases happen.

1. The parking brake released when the engine is running.
2. Press button (3) for 3 seconds between Step 3 and 4 during defaulting the reservation mode.
3. The valet mode applied after completing the reservation mode.
4. Doors opened after completing the reservation mode without remote engine start.
- 5.

#### ***LCD Remote Transmitter Function***

**Back Light** – Press button (4) once, the LCD back light will be on 3 seconds.

**Battery Save Mode** – Under the disarm mode, press button (2) and (4) once simultaneously, The remote transmitter chirps once. The LCD screen will be switched off after 70 seconds and enter into the battery save mode. Press any button to switch the remote transmitter on again.

**Vibration Mode** - Under any mode, press button (3) and (4) simultaneously to switch to Vibration or Audible Alert.

**Status Report** – Press button (2) and (3) once simultaneously, the main unit will send back updated vehicle status to the remote transmitter.

#### ***LED Status Indicate***

- Slow Flash : Arm/Alarm/Panic/Anti-Hijacking.
- Fast Flash : Auto Re-Arm
- Steady Light : Last Door Arming/ Sending the signals to the remote transmitter.
- No Light : Disarm

#### ***Factory Alarm Disarm Output***

If the vehicle has the factory fitted alarm, Use this wire to override the factory alarm before activate the FAI-8100 system.

**Important:** The factory fitted alarm must have the device of an input wire to receive signals from the FAI-8100 system.

#### ***Immobilizer By-pass Output:***

Nowadays, most of brand new cars have the immobilizer transponder device to enhance the security.

For these kinds of vehicles, The FAI-8100 system has the immobilizer by-pas output.

Before apply remote engine start or the reservation mode, the system will send constant signals to disable the factory

immobilizer. After the remote engine start succeeds, the system will stop sending signals. After the engine stops running during the reservation mode, the system will stop sending signals to disable the factory immobilizer.

**Important:** Factory immobilizer device must have an input wire to receive signals from the FAI-8100 system.

## ***Optional Programming Features***

The FAI-8100 has the additional features that can fit in different types of vehicles and your customized needs.

Read the below programming functions carefully to have the right options programmed for your vehicles and your needs.

- a) Under the system disarm mode, open and hold the door, and switch the ignition on-off, on-off, on-off and then stay On.
- b) Siren will chirp 2 seconds to confirm entering the programming option mode.
- c) To choose the function # 1 - 14, Press button (1) as many as its function # is indicated as listed below within 10 seconds after taking step# b. Each time you press button (1), the single short chirp shall follow up.  
For example, if you want to choose # 11 Start Mode Select, press button (1) 11 times.
- d) To confirm the selected mode, Press button (2). Siren will chirp as many as you press button (1) in step # C to show the function you chose.  
For example, if you press button (1) 11 times in step # C, 11 single short chirps will follow up.
- e) Now, you can make the selected mode programmed as factory default, default #1 or default #2 by pressing button (1), (2) or (3).  
When you press button (1), a single chirp will come out. Button (2) to program Default #1 of each function, two chirps and button (3) to program Default #3 of each function, three chirps to indicate the selected default programmed.  
The system will quit the programming option if there is no action made within 10 seconds your previous action taken or the ignition is off.

### ***Programming Option Table***

# of Button (1) pressed.	Function	Button (1) (Factory Default)	Button (2) (Default # 1)	Button (3) (Default # 2)
#1.	Last Door Arming	Disable	Enable	
#2.	Passive Lock	Disable	Enable	
#3.	Ignition Lock	Disable	Enable	
#4.	Door Unlock Time	1 Pulse	2 Pulses	4 seconds
#5.	Siren or Horn	Siren	Horn	
#6.	Alarm Time	30 sec.	60 sec.	
#7.	Dome Light Delay	Disable	15 sec.	40 sec.
#8.	Auto Re-arm	Disable	Enable	
#9.	Anti-Hijacking	Disable	Enable	
#10.	Car Type	Automatic	Manual	
#11.	Start Mode Select	Alternator	Tach	
#12.	Crank Time	0.6 Sec.	0.8 Sec.	1 Sec.
#13.	Start Running Time	10 Min.	20 Min.	
#14.	24-Hour Engine Start	Every 3 Hours	Every 6 Hours	Off

**Note:** The factory defaults are pre-programmed as per the third column (gray color box).

### ***Last Door Arming***

#### ***Steps to default Last Door Arming Enable:***

1. Under the disarm mode, open and hold the door, and switch the ignition on/off three times, and then switch to On.
2. Siren will chirp 2 seconds to confirm entering into the programming option mode.
3. Press button (1) once to select # 1 Last Door Arming Mode, a single short chirp will follow up.
4. Then press button (2) once to confirm this mode. a single short chirp will follow up.
5. Press button (2) once again to default the Last Door Arming Enable, the siren will chirp twice to confirm.
6. To quit the programming option mode, just switch off the ignition or do nothing.

If Last Door Arming Enabled,

Upon the doors are closed, LED starts to flash rapidly. Then siren will chirp once, the parking lights flash once, Starter kill on and armed automatically 30 seconds after the doors closed.

If Passive Lock enabled, the doors will be locked. Whereas, the doors will not be locked.

### ***Passive Lock***

#### ***Steps to default Passive Lock Enable:***

1. Under the disarm mode, open and hold the door, and switch the ignition on/off three times, and then switch to On.
2. Siren will chirp 2 seconds to confirm entering into the programming option mode.
3. Press button (1) twice to select # 2 Passive Lock Mode, a single short siren will follow up each time press button (1).
4. Then press button (2) once to confirm this mode., two single short chirps will follow up.
5. Press button (2) once again to default The Passive Lock Enable, the siren will chirp twice to confirm.

If Passive Lock enabled,

Upon the doors are closed, LED starts to flash rapidly. Then siren will chirp once, the parking lights flash once, starter kill on and doors locked automatically 30 seconds after the doors closed.

### ***Ignition lock***

#### ***Steps to default Ignition Lock Enable:***

Take the same procedure as above.

If Ignition lock Enabled,

The doors will be automatically locked 15 seconds after the ignition is on.

But, the doors will be not locked if opened within 15 seconds the ignition is on.

The doors will be unlocked immediately upon the ignition is turned off.

When the ignition is on, press button (1) to door lock or unlock.

### ***Door Unlock Time***

#### ***Steps to default Door Unlock Time Single, Double Pulse or 4 seconds:***

Take the same procedure as above.

It is not a user option to program. Consult with your installation center.

### ***Siren or Horn Output***

#### ***Steps to default Siren or Horn Output:***

Take the same procedure as above.

It is not a user option to program. Consult with your installation center in advance.

If horn selected, one extra relay shall be added.

If siren output selected, the system will send constant outputs.

If horn selected and defaulted, it has 0.5 second interval between each horn.

### ***Alarm Time***

#### ***Steps to default Alarm Time as 30 or 60 seconds:***

Take the same procedure as above.

### ***Dome Light Delay***

#### ***Steps to default Dome Light Delay as factory default, 15 seconds or 40 seconds:***

It is not a user option to program. Consult with your installation center.

The central locking system has the various dome light delay time according to different makers, brands or years of the vehicle. Program the right default depending on the dome light delay time the vehicle has.

Or just default the dome light delay disable and connect the instant wire of the vehicle to override the dome light delay time the vehicle has.

If the dome light delay programmed as disable,

All sensors will be activated 3 seconds after the system is armed.

If the dome light delay programmed as 15 seconds,

All sensors such as door, hood, trunk and shock except for ignition will be activated 15 seconds after the system is armed.

If the dome light delay programmed as 40 seconds,

All sensors such as door, hood, trunk and shock except for ignition will be activated 40 seconds after the system is armed.

#### ***Auto Re-Arm***

##### ***Steps to default Auto Re-Arm enable:***

Take the same procedure as above.

If Auto Re-Arm Enabled, the system will be automatically armed 30 seconds after the system is disarmed.

#### ***Anti-Hijacking Mode***

##### ***Steps to default Anti-Hijacking enable:***

Take the same procedure as above.

It is not a user option to program. Consult with your installation center in advance.

**Important : If the users want to use Anti-Hijacking Mode, the installer shall connect Starter Kill relay.**

Unless the starter kill is connected, the start motor will shut down when Anti-Hijacking Mode is operated.

It is a convenient feature to use when your vehicle is just stolen.

Press button (3) once when the engine is on.

LED starts to flash rapidly 15 seconds, then the parking lights start to flash and siren chirp in one cycle. But continue to sound and flash unless the car key is off. Then door will be locked, Starter Kill on and armed.

Press button (1) once to quit Anti-Hijacking mode.

#### ***Car Type***

##### ***Steps to default Car Type as Automatic or Manual:***

Take the same procedure as above.

It is not a user option to program. Consult with your installation center.

#### ***Engine Start Mode***

##### ***Steps to default Engine Start Mode as Alternator or Tach:***

Take the same procedure as above.

It is not a user option to program. Consult with your installation center.

If Tach Sensing (RPM) programmed,

- a) Perform the tach learning at first time before remote start.
- b) Make sure the Tach wire(Green) of the alarm system shall be connected to the negative of the coil as shown in wiring diagram.

#### ***Crank Time***

##### ***Steps to default Crank Time as 0.6, 0.8 or 1 second:***

Take the same procedure as above.

It is not a user option to program. Consult with your installation center.

Normally, the old and diesel vehicles need longer crank time to start engine.

However, if the engine doesn't start smoothly, please default the crank time longer.

#### ***Start Running Time***

##### ***Steps to default Start Running Time as 10 minutes or 20 minutes:***

Take the same procedure as above.

Depending on the defaulted engine running time, the engine will run 10 or 20 minutes and shut down automatically.

#### ***24-Hour Engine Start Mode***

##### ***Steps to default 24-Hour Engine Start Mode as 3 hours, 6 hours or off:***

Take the same procedure as above.

It is the most convenient feature to use in the cold winter season.

- a) Press button (1) and (3) once at the same time to activate 24-Hour Engine Start Mode, then siren will chirp once, lights flash once to confirm.

Depending on the defaulted value, the engine will automatically start every 3 or 6 hours in the 24- hour period.

- c) Press button (1) and (3) once again at the same time to deactivate this mode. Then siren will chirp twice and the parking lights flash twice.

Followings are 3 situations that the 24-hour engine start mode will be cancelled.

- a) When remote engine start.
- b) Doors are opened.
- c) The system is triggered.

# FAI-8100 2-Way Paging Alarm Wiring Diagram

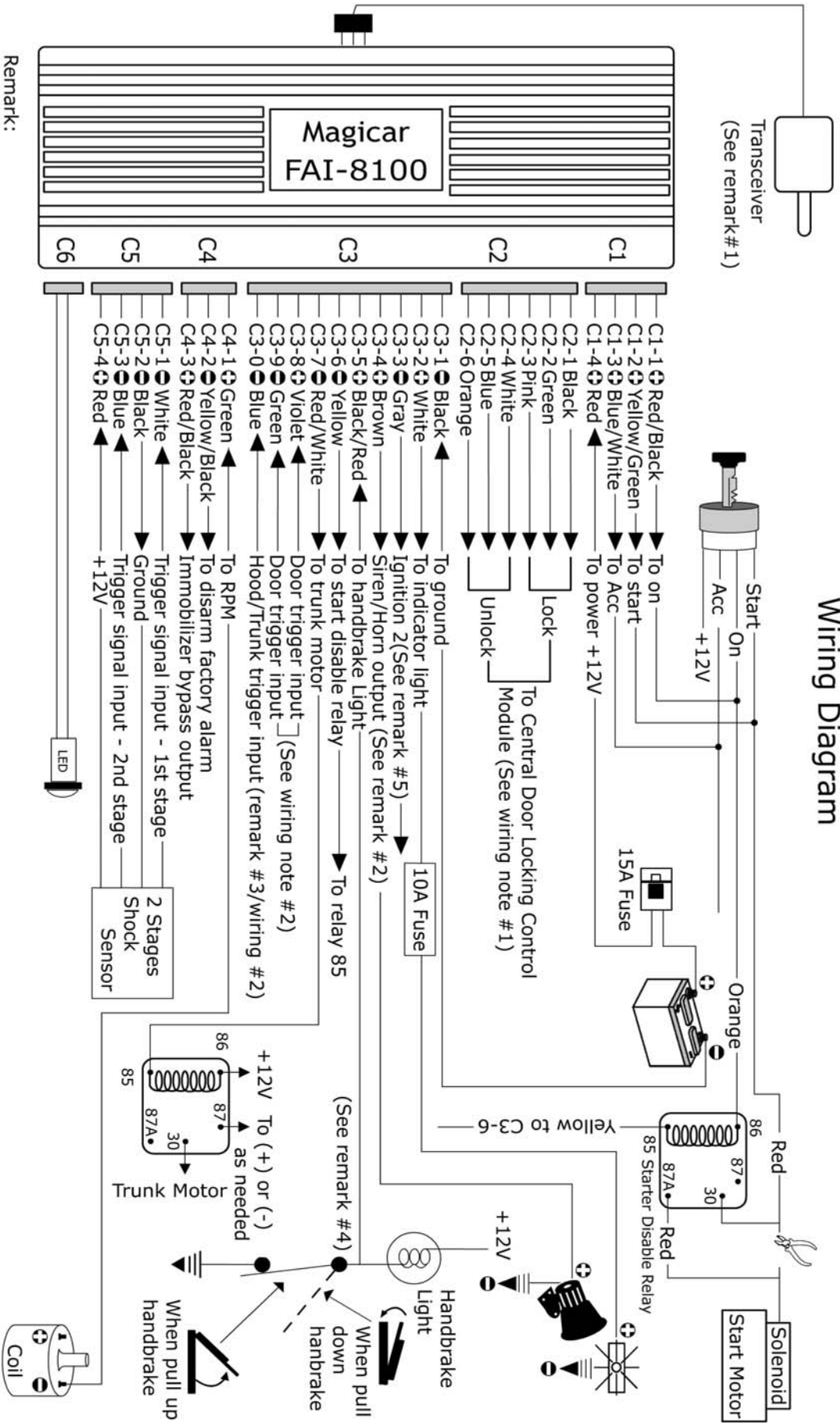

Remark:

- #1: Please get the transceiver away from any metal parts and also the shock sensor when installation
- #2: If connect to horn, please add one relay
- #3: Connect C3-0 to trunk lamp and hood parallel. Using a pin-switch for hood trigger.
- #4: Must connect C3-5 to ground otherwise the engine can't start with remotes
- #5: If your vehicle has ignition 2(Acc 2), this wire must be connected to ignition 2(Acc 2) of the vehicle

## Wiring Diagram