

Honeywell Vista 15SE

Wiring M2M's MiNi/MQ Series Cellular Communicators and Programming the Panel

CAUTION:

- It is advised that an experienced alarm installer programs the panel as further programming may be required to ensure proper performance and use of the full functionality.
- Do not route any wiring over circuit board.
- Full panel testing, and signal confirmation, must be completed by the installer.

NEW FEATURE: For MiNi/MQ Series Communicators, the status of the panel can be retrieved not only from the status PGM but now also from the Open/Close reports from the dialer. Therefore, wiring the white wire and programming of the status PGM of the panel is optional.

Wiring the white wire is necessary only if the Open/Close reporting is disabled.

IMPORTANT NOTE: The Open/Close reporting needs to be enabled during the initial pairing procedure.

Wiring the MiNi Series communicators to Honeywell Vista 15SE

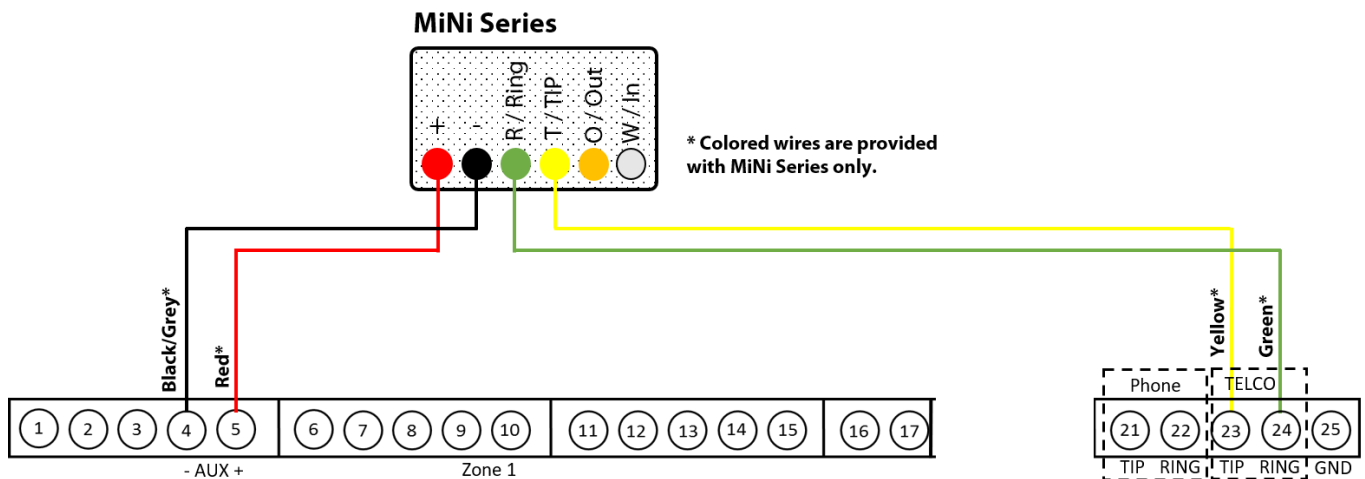

Wiring the MQ Series communicators to Honeywell Vista 15SE

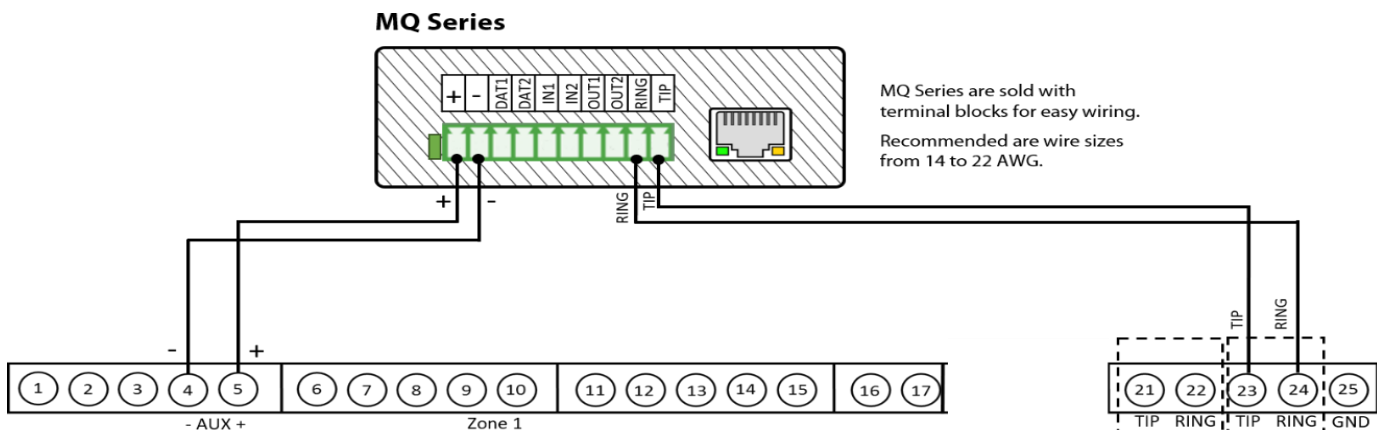

Programming the Honeywell Vista 15SE Alarm Panel via the Keypad

Enable Contact ID reporting:

Keypad Display	Keypad Entry	Action Description
DISARMED	4112800	To enter programming menu.
Installer Code	*41	To start configuring primary phone number.
Pri. Phone	123456*	Enter phone number value and press * to save and go back.
Field?	*43	To start configuring "Part. 1 Primary Subs. Acct. No."
Pri Subld	1234*	Enter account number value and press * to save and go back.
Sec Subld	*45	To enter "Phone system select" menu.
Phone Sys	1*	To select "Tone Dial" and go back.
Field?	*46	To enter "Report format" menu.
Rep Form Pri/Sec	7*	To select "Ademco Contact ID" for primary phone number.
Field?	*65	To go to "Open report code" setup.
Open Rpt	1*	To enable reporting for "Open" event.
Field?	*66	To go to "Arm Away/Stay Report Code" menu.
Awy/Sty Rp	1, 1*	To enable reporting for "Away/Stay" events.
Field?	*92	To go to "TLM" menu.
Telco Monitor	0*	To disable TLM and save.
Field?	*99	To exit programming mode.