

DSC Impassa (SCW9055, SCW9057)

Wiring M2M's MiNi/MQ Series Cellular Communicators and Programming the Panel

CAUTION:

- It is advised that an experienced alarm installer programs the panel as further programming may be required to ensure proper performance and use of the full functionality.
- Do not route any wiring over circuit board.
- Full panel testing, and signal confirmation, must be completed by the installer.

NEW FEATURE: For MiNi/MQ Series Communicators, the status of the panel can be retrieved not only from the status PGM but now also from the Open/Close reports from the dialer. Therefore, wiring the white wire and programming of the status PGM of the panel is optional.

Wiring the white wire is necessary only if the Open/Close reporting is disabled.

IMPORTANT NOTE: The Open/Close reporting needs to be enabled during the initial pairing procedure.

Wiring the MQ Series communicators to DSC Impassa

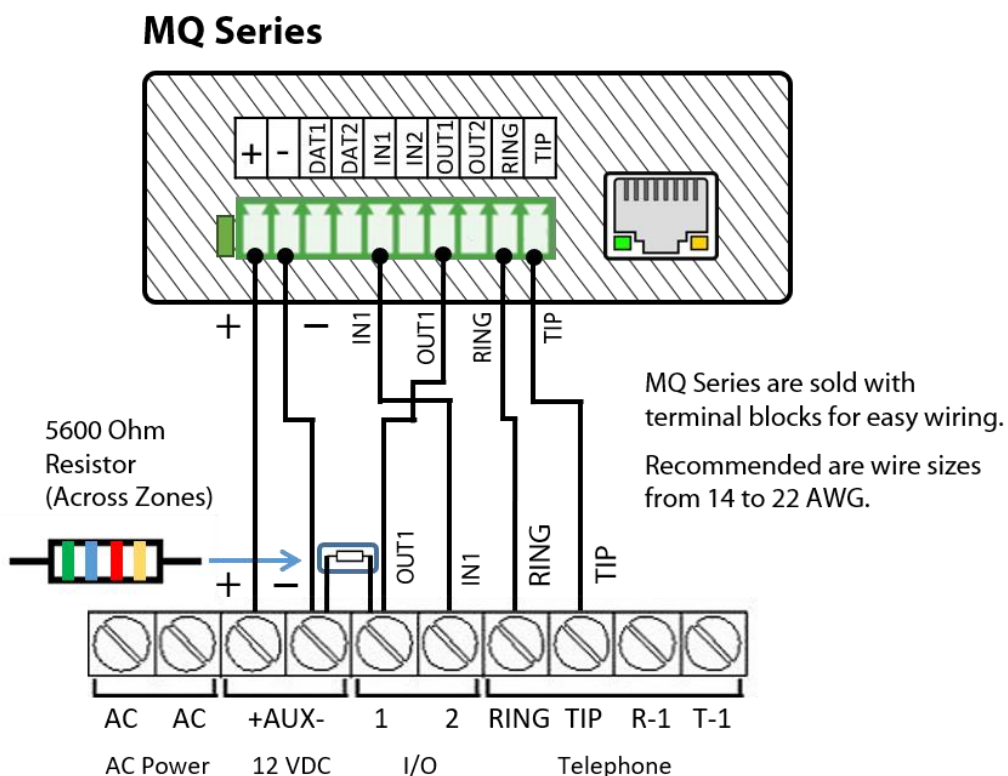

Wiring the MiNi Series communicators to DSC Impassa

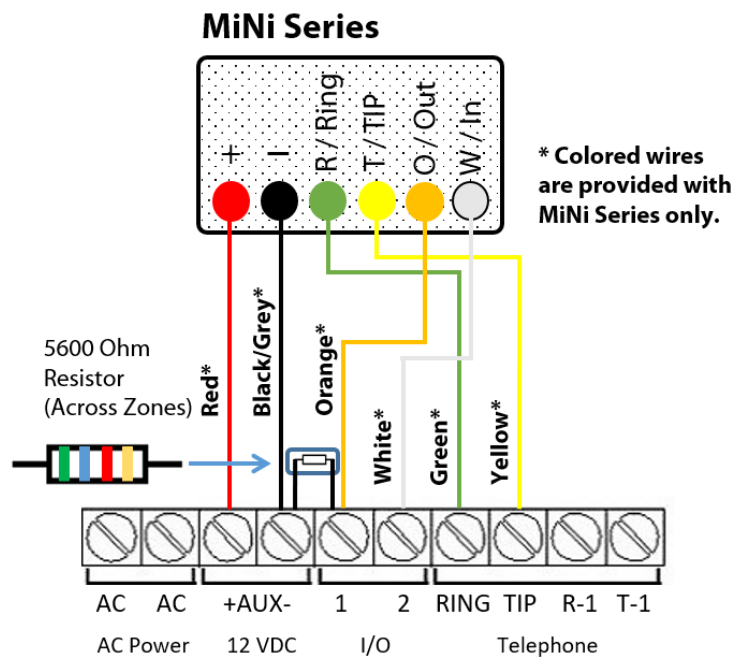

Wiring the MiNi Series with Ringer MN01-RNGR to DSC Impassa for UDL

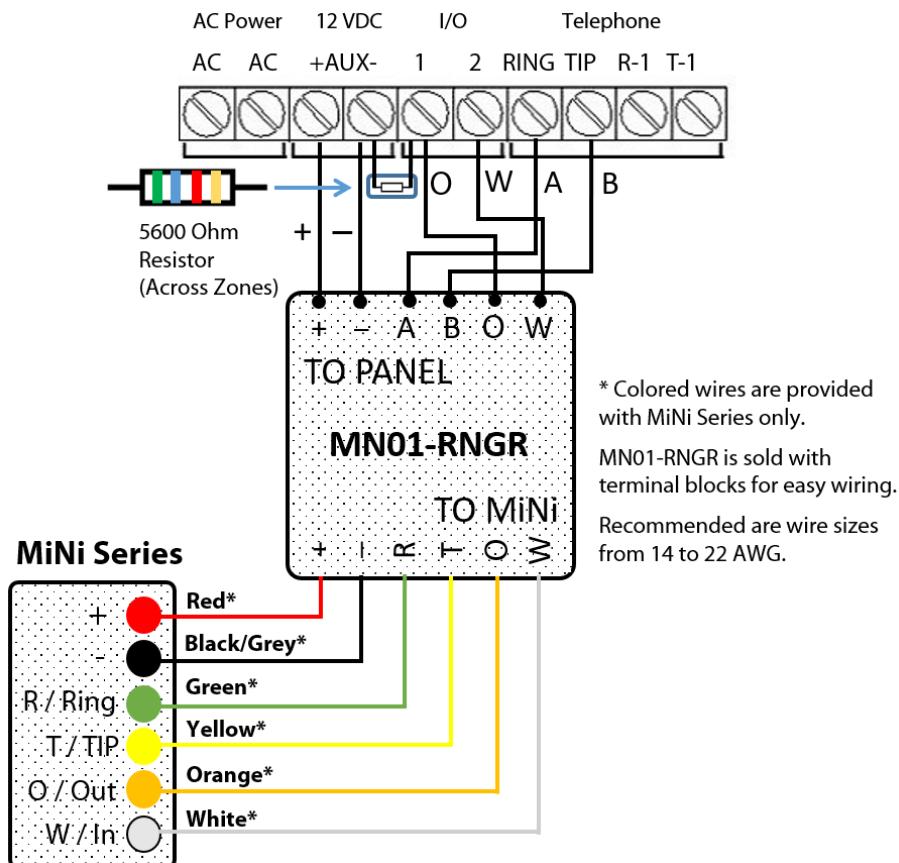

Programming the DSC Impassa Alarm Panel via the Keypad

Enable Contact ID reporting:

Keypad Display	Keypad Entry	Action description
Enter Section:	*85555	To enter in Programming mode
Enter Section:	015	To enter menu "Third System options".
Toggle Option:	7#	Option 7 must be off (TLM disabled).
Enter Section:	301	To enter menu" First phone number".
DFFFFFF	123456#	Enter actual or non-existing number (any number will do, 123456 is an example).
Enter Section:	310	To enter menu "System account code".
Enter data:	1111	Enter 4-digit account number (1111 is an example) to receive the events from
Enter Section:	350	To enter "Communicator Alarm Format" options.
Enter Data:	03030303	03 is for Contact ID (03030303 is to set all 4 phone lines).
Enter Section:	351	To program phone 1 communicator call direction.
Toggle Option:	1#	Toggle 1 to ON for alarms (it has to appear on screen).
Enter Section:	367	Open/Close Communicator Cell directions.
Toggle Option:	1#	Toggle 1 to ON to enable Open/Close reports (it has to appear on screen).
Enter Section:	380	Enter First Communication Options.
Toggle Option:	1#	Toggle 1 to ON, 3 to off to enable communications.
Enter Section:	381	Enter Second Communication Options.
Toggle Option:	7#	Toggle 7 to OFF, to enable automatic reporting. To manually program the reporting codes in the menu 381, enable option 7 to ON and then set the desired reporting codes in menus 320 to 348.
	#	Exit Programming mode.

Program Keyswitch zone and output:

Keypad Display	Keypad Entry	Action Description
Enter Section:	*85555	To enter in Programming mode
Enter Section	206	Enter Zone Assignment
Toggle Option	1	Toggle option 1 to ON to enable the Keyswitch zone.
Enter Section	003	Zone 33 Keyswitch (on zone 33 because the first 32 are wireless)
Enter Data :XX	22#	22 is for the Zone Type Keyswitch.
Enter Section	013	Enter First System Options (to select I/O as Input or PGM)
Toggle Option	1#	When panel is defaulted press the toggle buttons until 1 is ON and 2 is OFF.
Enter Section	133	Enter I/O Programming for zone 33 (First 32 are wireless zones)
Toggle Option	9	Press 9 to move to option 9-16.
Toggle Option	7#	Make sure that option 15 is selected (shows as 7 on the second screen). This standard mode of operations REQUIRES a resistor across the STC.
Enter Section:	009	Enter I/O Programming
Enter Data: XX	00	Enter 00 to program zone Type, I/O 1
Enter Data: XX	05	Enter 05 to program Armed Status on I/O 2, XX is default value
	#	Exit Programming mode.

Programming the DSC Impassa Alarm Panel via the Keypad for remote Upload/Download (UDL)

Program the Panel for Upload/Download (UDL):

Display	Keypad Entry	Action Description
Date / Time	*8 + Inst. Code	Enter programming menu. Default installer code is "5555"
Enter section	401	First downloading options toggle menu
Toggle option	1,3,6#	1 and 3 should be disabled. 6 should be enabled.
Enter section	403	DLS downloading access code. Default for Impassa is "905700".
Enter Hex Data	905700#	Set this field's value to its default.
Enter section	404	Panel ID code. Default for Impassa is "905700".
Enter Hex Data	905700#	Set this field's value to its default.
Enter section	405	Double call timer address
Enter Data	000	Disable double call
Enter section	406	Number of rings address
Enter Data	001	Set the panel to answer on the first ring.
	#	Exit Programming mode.