

Interlogix Concord 4

Wiring M2M's MiNi/MQ Series Cellular Communicators and Programming the Panel

CAUTION:

- It is advised that an experienced alarm installer programs the panel as further programming may be required to ensure proper performance and use of the full functionality.
- Do not route any wiring over circuit board.
- Full panel testing, and signal confirmation, must be completed by the installer.

NEW FEATURE: For MiNi/MQ Series Communicators, the status of the panel can be retrieved not only from the status PGM but now also from the Open/Close reports from the dialer. Therefore, wiring the white wire and programming of the status PGM of the panel is optional.

Wiring the white wire is necessary only if the Open/Close reporting is disabled.

IMPORTANT NOTE: The Open/Close reporting needs to be enabled during the initial pairing procedure.

Wiring the MiNi Series communicators to Interlogix Concord 4

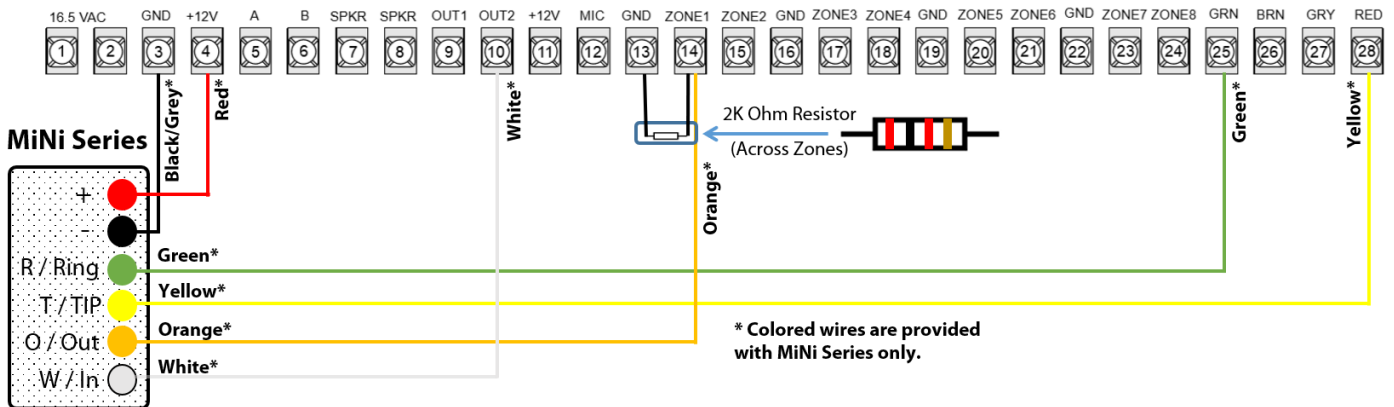

Wiring the MQ Series communicators to Interlogix Concord 4

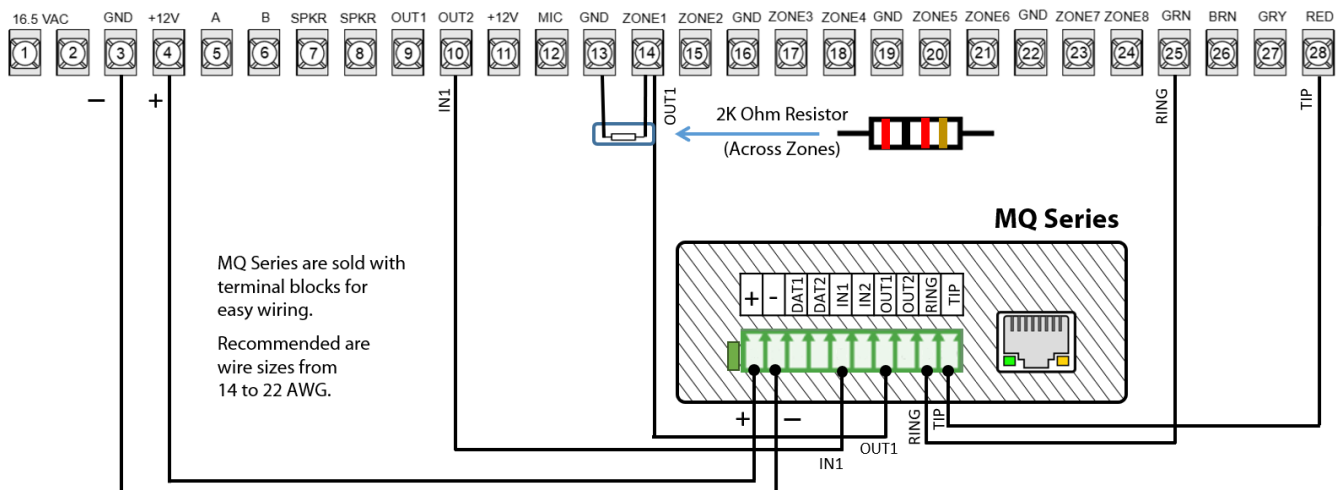

Programming the Interlogix Concord 4 Alarm Panel via the Keypad

Enable Contact ID reporting:

Keypad Display	Keypad Entry	Action description
Date and Time	8 4321 00	To enter programming mode.
System programming	01006	To display Reporting format.
Reporting Format "TYPE"	2, # ***	"TYPE" is the current programmed types, 2 is for CID, # to confirm, hit *** to get to System Programming.
System programming	01004	To display Open/Close RPTS.
Open/Close RPTS XX	2 #	XX is Current Status, 2 is for ON, # to confirm.
Open/Close RPTS ON	***	Return to System Programming.
System programming	06100	This displays opening reports status.
Opening Reports XX	2 #	XX is the current status, 2 is for ON, # to Confirm.
Opening Reports ON	***	Return to System Programming.
System programming	06101	This displays closing report status.
Closing reports XX	2 #	XX is for current status, 2 is for ON.
Closing reports ON	***	Return to System Programming.
Exit System Programing	BBBB#	Press BBBB (4 times down in the menu) to exit System programing.
Date and Time	8432103##	To set account number for partition 1.
Account number XXXX	1234#	Enter your desired account number (1234 is an example), # to save.
	**	To get back to account number.
CS Phone 1	B##	To move through the menu to go to CS Phone, ## to select Phone 1.
CS Phone _____	123456#	Enter an actual phone or any number of your choice, # to save.
CS Phone	**	Exit to main menu.
CS Phone	BB	Navigate to End Programming.
End Programming	#	Press # to confirm.

Program Keyswitch zone and output:

Keypad Display	Keypad Entry	Action Description
Date and Time	84321	To enter system programming.
System programming	0014	This enters the keyswitch sensor area.
Key Switch Sensor	X#, B	X=Zone Number 1-8, # to confirm, press B to get to keyswitch style.
Key Switch style transition	B ***	Press B until the Display shows TRANSITION. Then press * a few times to get back to System Programming.
System Programming	080	Enters the Learn Sensor Menu.
Learn Sensors	#	# opens this menu.
Sensors PTN 1	#	This is the partition area, with 1 as default. Do not change if 1.
Sensor Group 0	28#	Choose sensor group 28.
Trip Sensor X	*	Navigate to chosen zone X (1-8), Short Zone X wire to GND wire. Wait for the panel to beep, then press * until the Learn Sensors prompt is displayed.
Learn Sensors	A	To get to edit sensor area.
Edit Sensors	#	View sensor 1.
S1 P1 G28 NO HW KEY	***	Get back to System Programming.
System Programming	1121#	Displays output 2 Status.
Output 2 Item 0 "Status"	11#	Output 2 will be armed (ex 11- ARMED).
Output 2 Item 1,	****	Press * a few times to get back to system programming (11 – ARMED).
System Programming	11111	Displays configuration for Output 2.
Configuration XXXXXX	00903 #	Enter 009=Arm Event, 03=Sustained Response, # to confirm.
Configuration 00903	****	Press * a few times until you get back to System Programming.