

SHIELD TECH SECURITY FAI-822 and FAI-586 DIAGRAMS

www.shieldtechsecurity.com (Revision 1.0)

CONNECTING FAI-822 to FAI-586 DIAGRAM

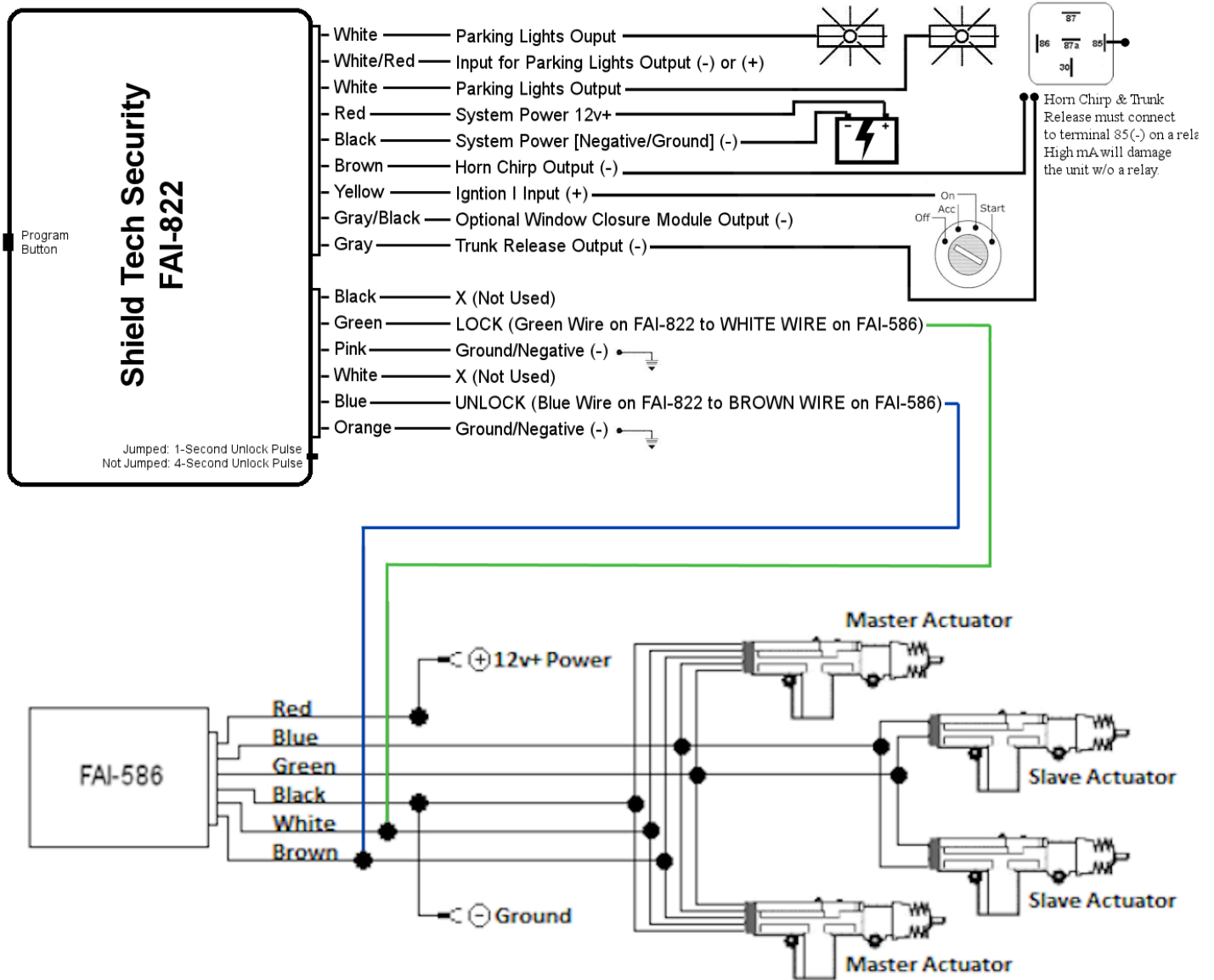

FREE VEHICLE WIRING DIAGRAM

DOWNLOAD SELF-HELP GUIDES & A VEHICLE WIRING DIAGRAM AT www.shieldtechsecurity.com/diagrams

**Express Service Code:
Provided w/ shipped keyless entry kit.**

The express service code is valid for at least 90 days. If expired, please contact us for assistance.

Installations should be attempted by experienced security installers only. Information contained is without any representation of warranty. Proper installation remains the sole responsibility of the installer. Shield Tech Security assumes no liability or responsibility resulting from an improper installation, even in reliance with the information contained in this guide.

FAI-822 WIRING DIAGRAM

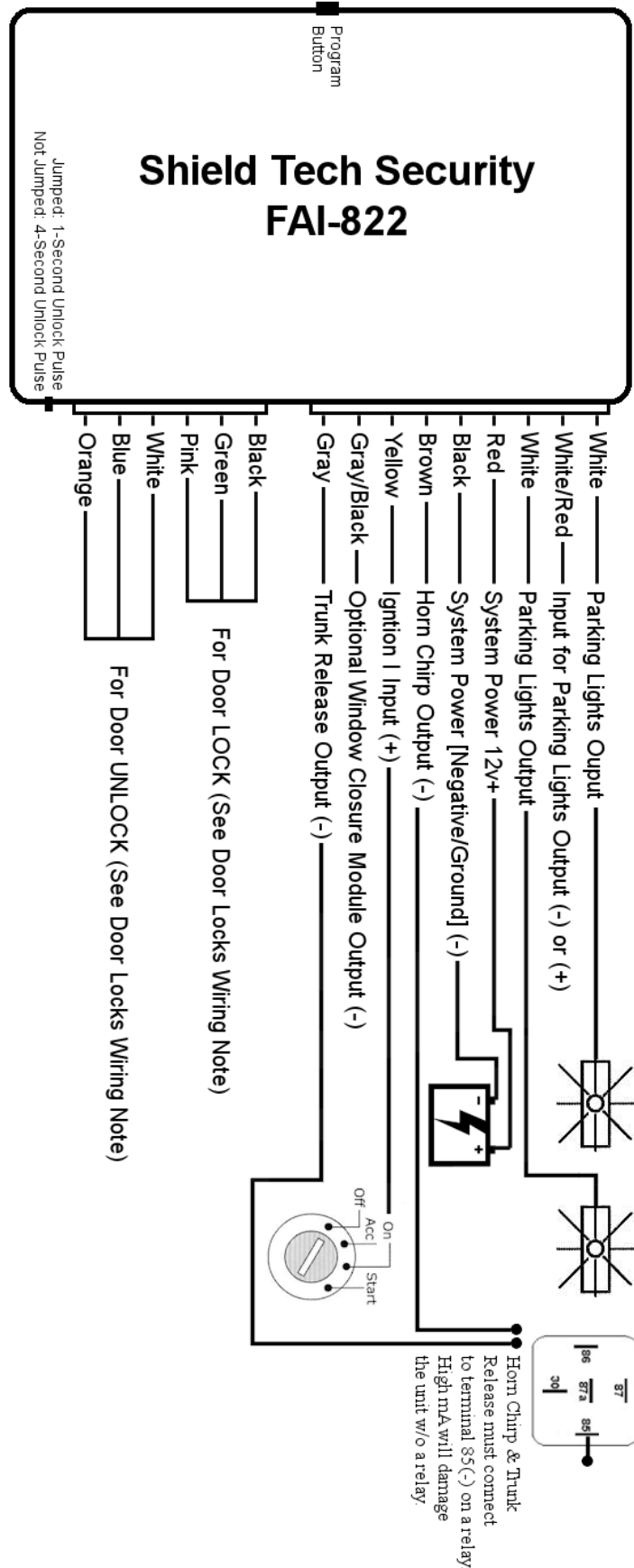

Installations should be attempted by experienced security installers only. Information contained is without any representation of warranty. Proper installation remains the sole responsibility of the installer. Shield Tech Security assumes no liability or responsibility resulting from an improper installation, even in reliance with the information contained in this guide.

FAI-822 DOOR LOCKS WIRING NOTE

4.07 Lock & unlock wire

Diagram #A
Original built-in central power lock

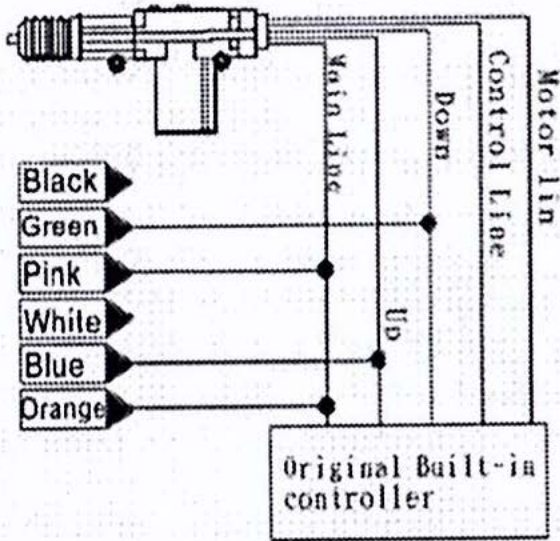

Diagram #B

Original built-in central power lock & electric power lock switch were installed for example: CHRYSLER

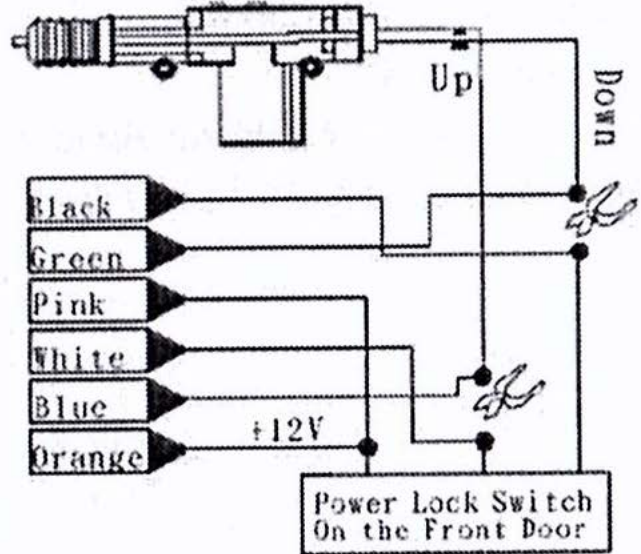

Diagram #C

Original built-in central power lock & only a switch existed inside of the front door. A motor and the control elvel were required

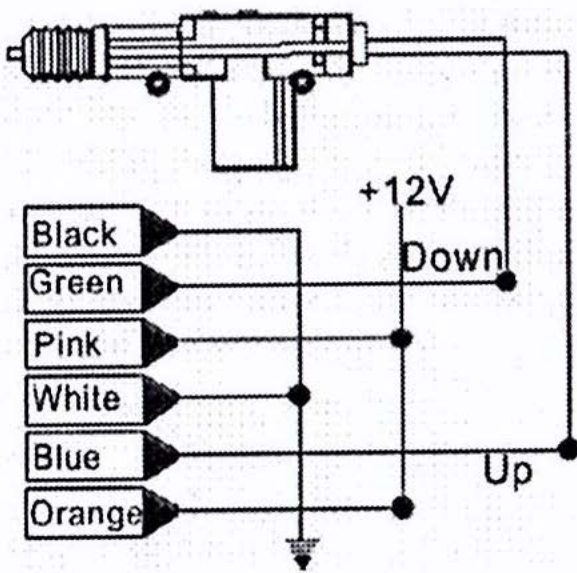
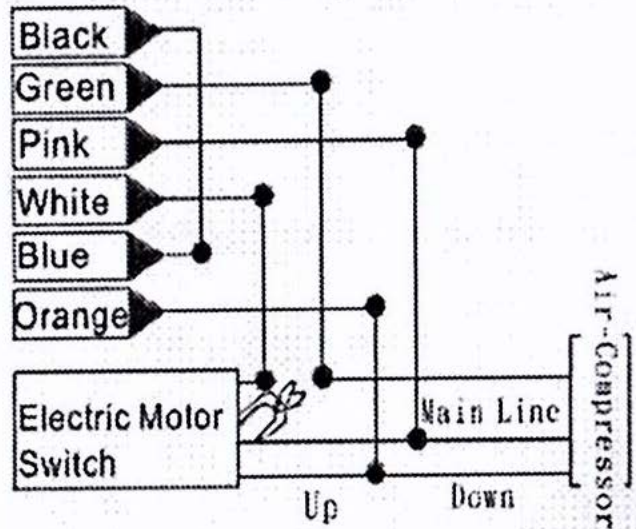

Diagram #D

Original built-in central power lock & using compressor to control the switch.

For example: BENZ, AUDI

(Note: Active time 3.5 sec.)



Installations should be attempted by experienced security installers only. Information contained is without any representation of warranty. Proper installation remains the sole responsibility of the installer. Shield Tech Security assumes no liability or responsibility resulting from an improper installation, even in reliance with the information contained in this guide.

FAI-586 WIRING DIAGRAM

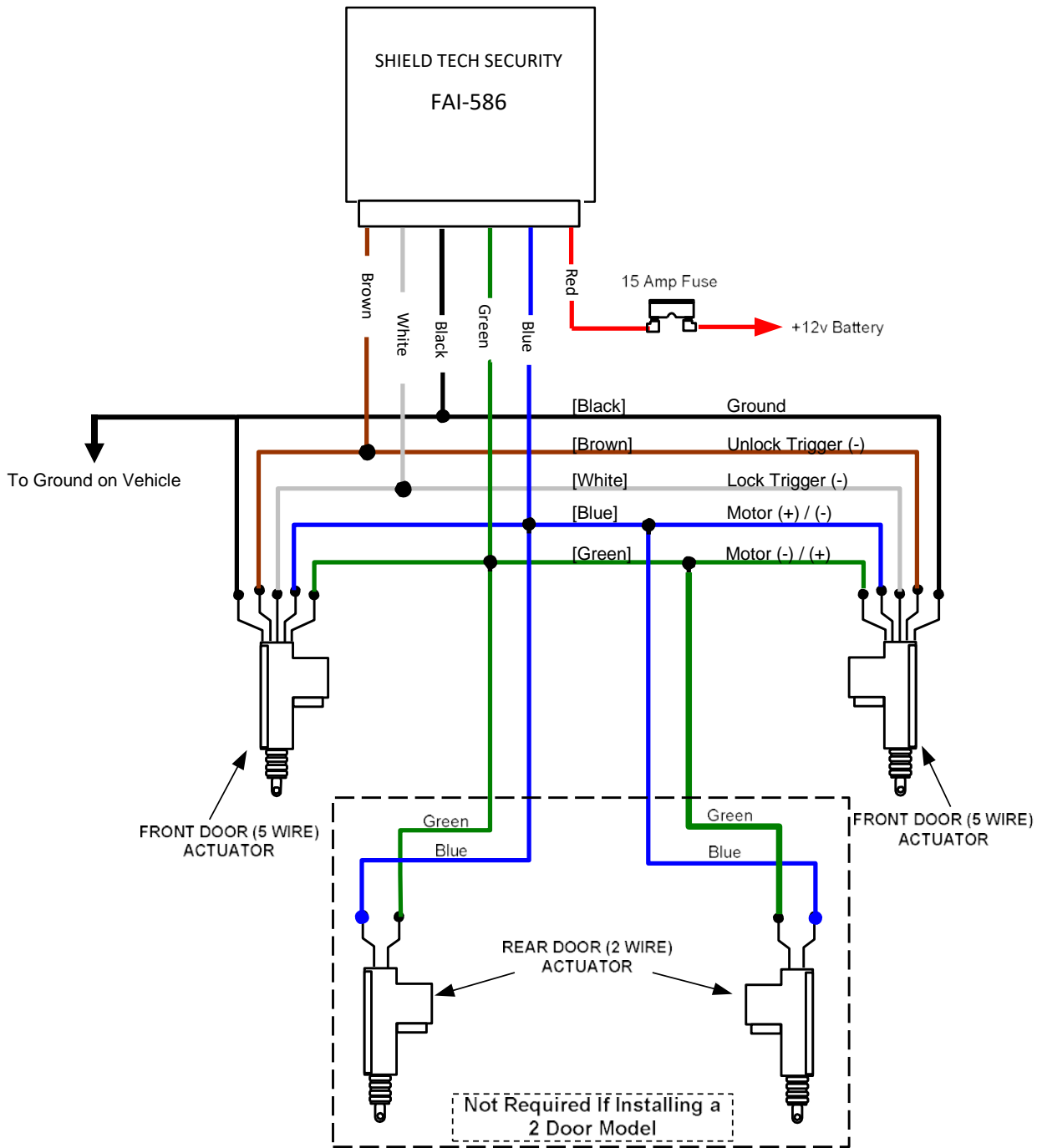

MORE INFORMATION

Please visit www.shieldtechsecurity.com for more information.

Installations should be attempted by experienced security installers only. Information contained is without any representation of warranty. Proper installation remains the sole responsibility of the installer. Shield Tech Security assumes no liability or responsibility resulting from an improper installation, even in reliance with the information contained in this guide.